



higher education & training

Department:
Higher Education and Training
REPUBLIC OF SOUTH AFRICA

NATIONAL CERTIFICATE PATTERN CONSTRUCTION N5

(10010515)

**2 October 2020 (X-paper)
09:00–12:00**

REQUIREMENTS: White typing paper

**Calculators may be used.
Candidates need drawing instruments.**

This question paper consists of 15 pages and 4 addenda.

163Q1B2002

DEPARTMENT OF HIGHER EDUCATION AND TRAINING
REPUBLIC OF SOUTH AFRICA
NATIONAL CERTIFICATE
PATTERN CONSTRUCTION N5
TIME: 3 HOURS
MARKS: 200

INSTRUCTIONS AND INFORMATION

1. This question paper consists of TWO sections:

SECTION A: 50 marks
SECTION B: 150 marks
GRAND TOTAL: 200 marks
 2. All the questions in SECTION A are COMPULSORY.
 3. In SECTION B answer QUESTION 5.1 OR QUESTION 5.2.
 4. Read all the questions carefully.
 5. Number the answers according to the numbering system used in this question paper.
 6. Write neatly and legibly.
-

SECTION A (COMPULSORY)**QUESTION 1**

1.1 Various options are given as possible answers to the following questions. Choose the answer and write only the letter (A–D) next to the question number (1.1.1–1.1.10) in the ANSWER BOOK.

1.1.1 The complete record of each design; is used to give the garment price as well as wholesale price:

- A Fabric estimation
- B Design specification sheet
- C Cost sheet
- D Style analysis 

1.1.2 Ability to read a fashion sketch of printed design:

- A Control dart
- B Style analysis
- C Fabric estimation
- D Block construction

1.1.3 A graphical representation of a designer sketch in correct proportion of the human figure form:

- A Styled pattern
- B Production pattern
- C Pattern drafting
- D Production drawing

1.1.4 The production from a single master pattern, a set or range of sizes of the same pattern:

- A Trade block
- B Pattern grading
- C Marker
- D Secondary block

1.1.5 The outlines for the different block sections such as front and back bodice:

- A Pattern lines 
- B Construction lines
- C Pattern cutter
- D Pattern chart

1.1.6 Straight, vertical and lateral lines which form the basis for the location of system points for height, width, and girth factors in the production of basic block patterns:

- A Pattern grading
- B Master pattern
- C Pattern lines
- D Construction line

1.1.7 The changing of the basic block to fit various figure disproportions:

- A Pattern designing
- B Pattern manipulation
- C Pattern adaptation
- D Styling



1.1.8 The length of paper containing a copy of all pattern pieces to be cut at one time:

- A Production pattern
- B Marker
- C Pattern grading
- D Styled pattern

1.1.9 To approximate quantities of fabric necessary for individual garments:

- A Fabric estimation
- B Pattern drafting
- C Pattern pieces
- D Pattern grading





1.1.10 A record of the finishing requirements for each design to ensure that the garments meet company standards:

- A Pattern grading
- B Fabric estimation
- C Cost sheet
- D Design specification sheet

(10 × 1) (10)

- 1.2 Choose an item from COLUMN B that matches a description in COLUMN A. Write only the letter (A–L) next to the question number (1.2.1–1.2.10) in the ANSWER BOOK.

COLUMN A		COLUMN B	
1.2.1	The act of slashing and spreading or pivoting the pattern pieces to alter its original shape	A	dart legs
		B	selvedge
1.2.2	The finished pattern that contains all the features related to the design	C	squaring
		D	dart intake
1.2.3	The two lines that form an open space at the pattern's edge creating a wedge shape	E	pivot
		F	pattern manipulation
1.2.4	The space between the two legs to take up fullness and release fabric where it is needed	G	cutting symbol
		H	grain line 
1.2.5	Shown at the end of slash lines	I	scye
1.2.6	Used to indicate the cutting; appears on the slashing line	J	bias
1.2.7	The narrow, firmly woven and finished strip on both lengthwise grain edges of woven fabrics 	K	pattern design
1.2.8	The area on the bodice where the armhole is situated	L	spots
1.2.9	The swinging of an arc from a certain fixed point		
1.2.10	Slanting or diagonal line cut or sewn across the weave of the cloth		

(10 × 1) (10)

- 1.3 Indicate whether the following statements are TRUE or FALSE by writing only 'True' or 'False' next to the question number (1.3.1–1.3.5) in the ANSWER BOOK.

- 1.3.1 Wedge is the tapered insert into a pattern piece to create a flare.
- 1.3.2 Ease is the even distribution of fullness when forming gathers.
- 1.3.3 Arrows are used for indicating the direction of moving the pattern parts after slashing in pattern making.



1.3.4 Control dart refers to shaping of the side seams, and darting of front and back of the garment to shape the figure at the waistline.



1.3.5 Bust prominence is the most protruding part of the hips.

(5 × 1) (5)

QUESTION 2

2.1 Briefly explain how to take the following measurements on a man’s figure. Write your answer next to the question number (2.1.1–2.1.5) in the ANSWER BOOK.

2.1.1 Around neck

2.1.2 Trousers, waist to ground

2.1.3 Trousers, rise height

2.1.4 Around upper arm



2.1.5 Around calf

(5 × 3) (15)

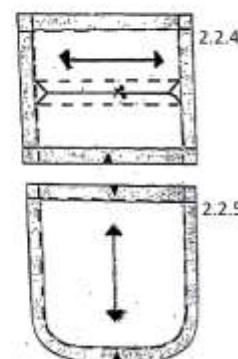
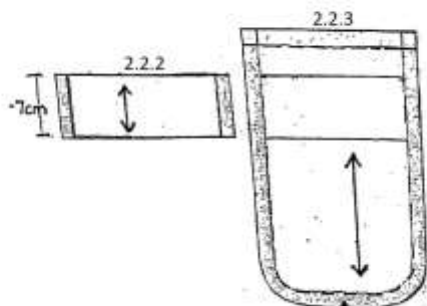
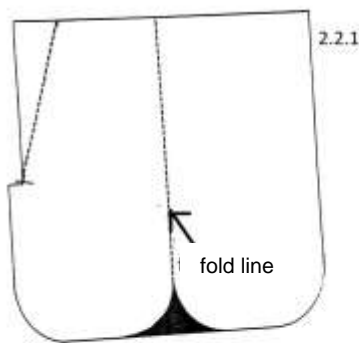

2.2 Label the following trouser pocket pattern pieces. Write only the word or words next to the question number (2.2.1–2.2.5) in the ANSWER BOOK.



(5 × 2) (10) [50]

TOTAL SECTION A: 50

SECTION B

1. All the drafts must be done in the specified scale.
2. Drafts **MUST** be done on **WHITE TYPING PAPER**. Use a black fineliner pen to make clear construction lines. Do not cut out the drafts. **PASTE** the draft(s) into the **ANSWER BOOK**. 
3. It is not necessary to trace any of the blocks for planning and manipulation. Enough basic blocks are provided for the planning and manipulation. Use the **WHITE TYPING PAPER** for manipulations.
4. Manipulations must be pasted directly into the **ANSWER BOOK**. Then add seam and hem allowances, if required.
5. No loose parts will be marked.
6. Number the answers according to the numbering system used in this question paper. 
7. Do not use red or green ink.

QUESTION 3

Draft the **MEN'S TROUSER BLOCK**, on **FIFTH SCALE**. Use the following measurements and instructions.



MEASUREMENTS:

Seat	:	101,5 cm	
Inside leg		86,5 cm	
Body rise		28,5 cm	
Waist		81,5 cm	
Knee width		52 cm	
Bottom width		48,5 cm	
Waistband width		5 cm	
SCALE		Half the seat (50,75 cm)	

INSTRUCTIONS

Mark point 0 approximately 50 cm downwards from the top edge and 30 cm inside the right hand margin of a sheet of paper. Square to the left of 0.

Topside (Front)



- 0-1 = $\frac{1}{2}$ of the scale to the left of 0 on the horizontal line (25,4 cm) 
- 1-2 = $\frac{1}{6}$ of the scale to the left on the horizontal line (8,5 cm)
- 1-3 = $\frac{1}{6}$ of the scale to the right on the horizontal line (8,5 cm). Square up and down from 3 (crease line).
- 3-4 = Body rise minus waistband depth upward on the vertical line (23,5 cm). Square to the left and right (waistline)
- 3-5 = $\frac{1}{2}$ inside leg minus 5 cm downward (38,2 cm). Square to the left and right (knee line).
- 3-6 = Inside leg measurement downward on the vertical line (86,5 cm). Square to the left and right.
- 1-7 = Square a line upward to cut the line from 4.
- 1-8 = 1,2 cm to the left. Square a line upward to cut the line from 4 and mark point 9.
- 9-10 = $\frac{1}{4}$ waist dimension plus 2,5 cm (for pleats) to the right (22,9 cm). Mark out 3 cm down from 4 for the pleat centre line. 
Construct a 1,2 cm pleat width on either side of this line.
Bisect the angle on 8 to the left and mark point 11 up the bisector. Half the measurement 8 to 2 (3,6 cm).
Curve from 2 to 11 and up to touch the line and straight up to 9 for the front crotch line.
- 5-12 = $\frac{1}{4}$ knee width to the left (13 cm)
- 6-13 = $\frac{1}{4}$ bottom width to the left (12,1 cm). Join 12 to 13 with a straight line. Join 2 to 12 with a slight inward curve to complete the inside leg seam.
- 5-12A = $\frac{1}{4}$ knee width to the right (13 cm)
- 6-14 = $\frac{1}{4}$ bottom width to the right (12,1 cm). Complete the outside leg seam with a curve out from 10 to 0. Curve slightly in from 0 to 12A then straight down to 14.

Underside (back)

Indicate the underside with a broken line.

- 0-15 = 2 cm to the right 
- 12A-16 = 1,2 cm to the right
- 14-17 = 1,2 cm to the right
- 2-18 = $\frac{1}{12}$ scale plus 1 cm (5,3 cm) to the left on the horizontal line
- 18-18A = 1 cm squared down
- 12-19 = 1,2 cm to the left
- 13-20 = 1,2 cm to the left

Complete the inside leg seam: Curve inward from 18A to 19, straight down to 20. Extend the line from 10 to the right.

- 10–21 = 2 cm to the right 
 Place the set square on 2 to touch 9 and 21.
 Dot in the right angle of the set square from 2, through 9 to 21. Mark 22 on the 90° angle.
- 22–23 = 4 cm downwards on the dotted line
- 21–24 = $\frac{1}{4}$ waist dimension, plus 2,5 cm for the back dart (22,9 cm), measured to the left from 21 to 23. Curve the underside waistline from 21 to 24.
- 21–25 = 12 cm along the waistline to the left
- 25–26 = 7 cm squared down for dart centre line 
 Construct a dart with width 1,2 cm on both sides of 25.
 Draw in the back dart.
- Curve the underside outside leg seam: From 21 slightly curve outward to 15, inward to 16 and straight down to 17.
- Curve the hemline from 17 to the left, 1 cm downward at 6 and up to 20.
- 27 = Midway up on the dotted line between 2 and 9, where the dotted line cuts the front crotch line
- 27–28 = 2 cm square to the right

Complete the underside-crotch seam line:
 Curve from 18A through 2 to 28 and then straight to 24.

Label the block.
 Add grainline.
 Indicate the crease line. 
 Indicate centre front crotch.
 Indicate centre back crotch.

[40]

QUESTION 4

Study the sketch below of the MEN'S CASUAL SHIRT SLEEVE, size 38, and answer the questions.

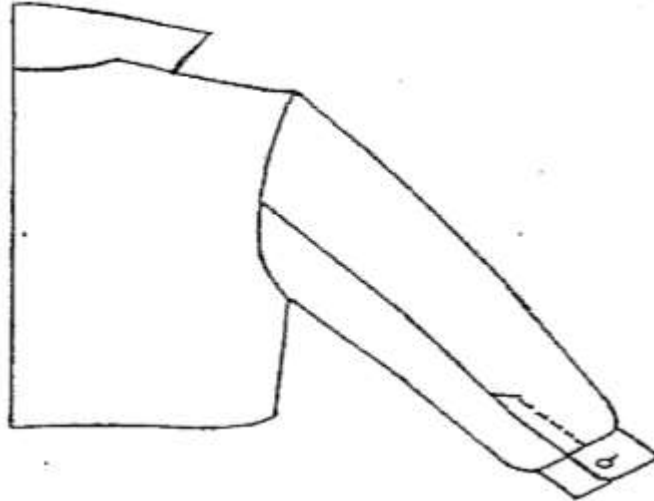

Use the MEN'S CASUAL SLEEVE block, size 38, on ADDENDUM A (attached) and submit the following constructions to FIFTH SCALE:

- 4.1 Planning stage of the shirt sleeve (15)
- 4.2 Planning stage of cuff  (10)

Use the following measurements and instructions:

SLEEVE

Mark back pitch (BP) and front pitch (FP) on the sleeve block.

- A = At the base of back opening of the sleeve at cuff line
- B = 5 cm measured upward from back pitch on the sleeve head
Join A to B for seam line.
Draw elbow line in broken lines.
- C = At elbow line, where line A and B cross
- A-D = 2 cm to the left at cuff line
Join B, C and D for back sleeve. 
- A-E = 2 cm to the right at cuff line
Join B, C and E for front sleeve.

[25]

QUESTION 5

Answer either QUESTION 5.1 or QUESTION 5.2.



5.1 Study the sketch below and manipulate the LADIES' TAILORED SINGLEBREASTED JACKET in FIFTH SCALE. Use the LADIES' JACKET BLOCK on ADDENDUM B.

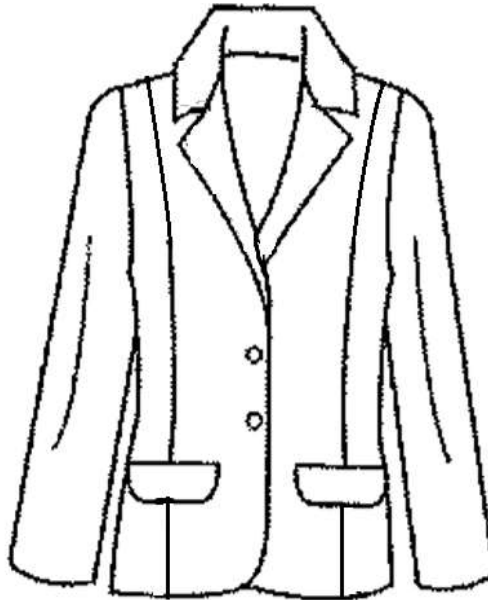

5.1.1 Submit the planning for the front jacket.



(23)

5.1.2 Submit the final for the top collar and under collar.

(12)

MEASUREMENTS

Breakpoint	=	16 cm
Button stand	=	2 cm
Half back neck	=	9 cm
Collar stand at centre back	=	2,5 cm
Total collar width on centre back	=	8 cm



INSTRUCTIONS

- A = 16 cm measured downwards on centre front from the neckline
 A-B = 2 cm squared to the right for the button stand

Square down to the hemline from B and mark point C.

Mark the buttonhole position.

Mark the neck point D (shoulder point).



Draw a broken line down from D = 9 cm long, parallel to centre front and mark point E.

Extend the shoulder line to the right.

- D-I = 2 cm to the right on the extended shoulder line

Join B to I and extend the line to the top.

- I-J = 9 cm (half back neck) measured upwards

Squared to the right and to the left from point J

- J-K = 2,5 cm measured to the left. Join K to D with a slight curve.

- J-L = 5,5 cm measured to the right

- L-L₁ = 6 mm measured upwards

Join K to L₁.

- E-E₁ = 1,2 cm measured to the left (1,2-2,5 cm)

Join D to E₁.

Square to the right on the D-E₁ line



- E₁-F = 14,5 cm measured to the right

Join F with the neckline curve.

- F-G = 3,5 cm measured to the left

Draw a line with an angle from G for the collar point.

- G-H = 3,5 cm on the line from G

Join L₁ to H for the collar style line.

Join F to B for the lapel style line.

Move the control dart to the mid shoulder

Draw the princess line from the control dart point to the waist dart point down to the hemline

Draw in a facing: 5 cm on the shoulder line and at the hemline.

To separate the collar from the bodice section, trace from **G-D-K**.

UNDER COLLAR – Trace on the true bias with a C.B. seam
TOP COLLAR – Trace on straight grain without a C.B. seam



OR

5.2 Study the sketch below of the MAN'S CASUAL JACKET,



Use the photocopies of the MAN'S CASUAL JACKET, front and sleeve blocks, size 38 on ADDENDUM C (attached) and submit the following manipulation of the sketch, to FIFTH SCALE.



- 5.2.1 Planning stage of the jacket front (18)
- 5.2.2 Planning stage of sleeve (10)
- 5.2.3 Final pattern of front yoke (7)

Use the following instructions and measurements:

Yoke	10 cm measured from centre front neck point downward Square in to the left to touch the armhole.
Jacket length	40 cm measured downwards from the yoke on the centre frontline Square in to the seam for the new hemline.
Elastic casing	5 cm – complete an elastic casing depth/allowance
Sleeve length	45 cm Increase in width 2 cm at cuff edge, on all sides of sleeve. Shoulder length extension for dropped shoulder is 2 cm. Add 5 cm for elastic casing.
Seam allowance	1,5 cm and hem allowance 3 cm



DRAW IN GRAIN LINES AND LABEL THE PATTERN PIECES



[35]

QUESTION 6

Study the sketch of the dress below. Use ONE PIECE DRESS BLOCK on ADDENDUM D. In FIFTH SCALE, manipulate the FRONT of the PRINCESS LINE DRESS using the following measurements and instructions.

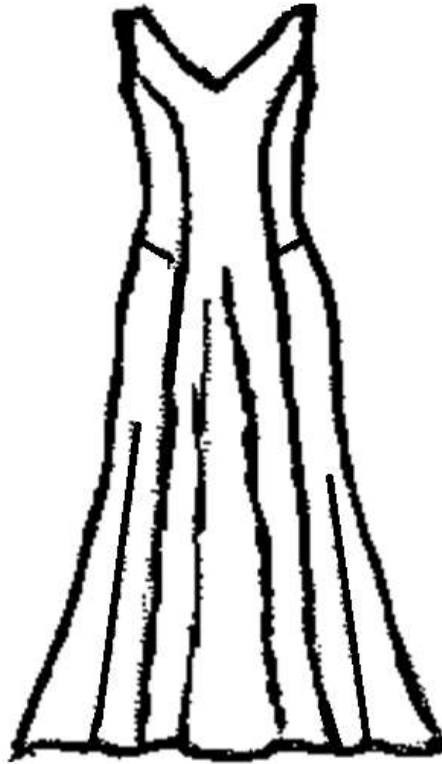

6.1 Submit the planning of the dress front.

(35)



6.2 Submit the final of a side seam panel.

(15)

MEASUREMENTS

Seam allowance		1,5 cm
Hem allowance		2 cm
Facing depth		5 cm

[50]

INSTRUCTIONS

Planning

Mark the centre front.

Measure down 8 cm from the neckline widening the neckline by 1 cm.

Redraw the neckline.



Mark the waistline.

Measure $\frac{1}{2}$ of the armhole for the princess line and draw the curve line to the bust point.

Close the bust control dart.

Draw the princess line.

Indicate the slash from the armhole through the dart point up to the waist.

Measure 5 cm down from the waistline on the side seam and draw the line from the side seam to the end of the waist suppression dart point.

Draw the 5 cm facing, 5 cm at the centre front and side seam.



Draw the combined facing.

Extend the princess line up to the hem from the waist suppression dart point to the new hemline.

Extend the dress length 80 cm from the waist down to the hem.

Add 5 cm flare at the side seam hemline.

Add 8 cm flare to each side of the panel line.

Indicate the slash lines.

Label the pattern, add the grain line.

TOTAL SECTION B: 150
GRAND TOTAL: 200

ADDENDUM A

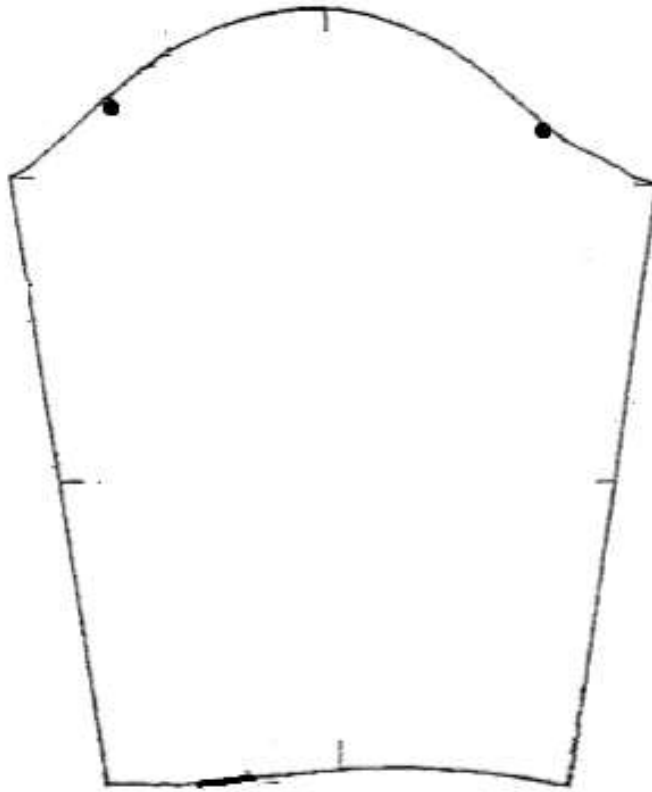

ADDENDUM B

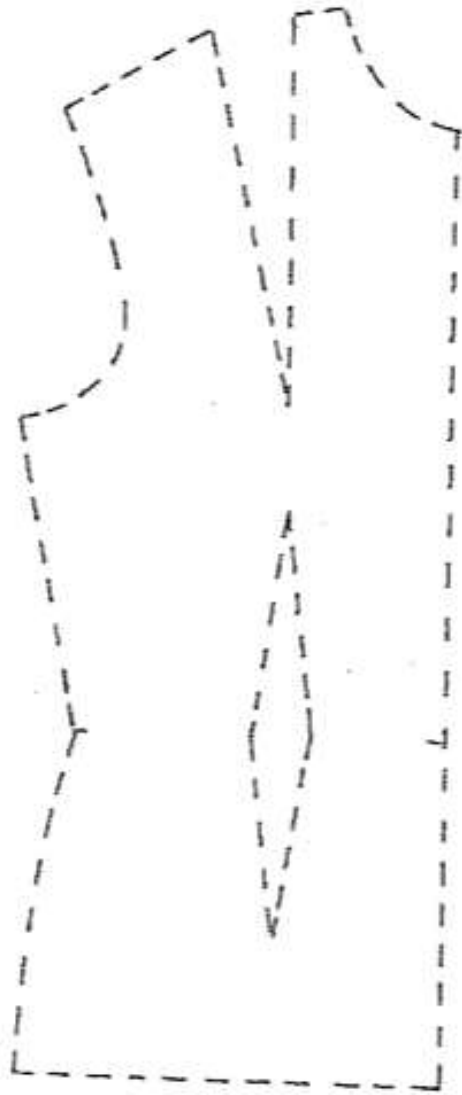

ADDENDUM C

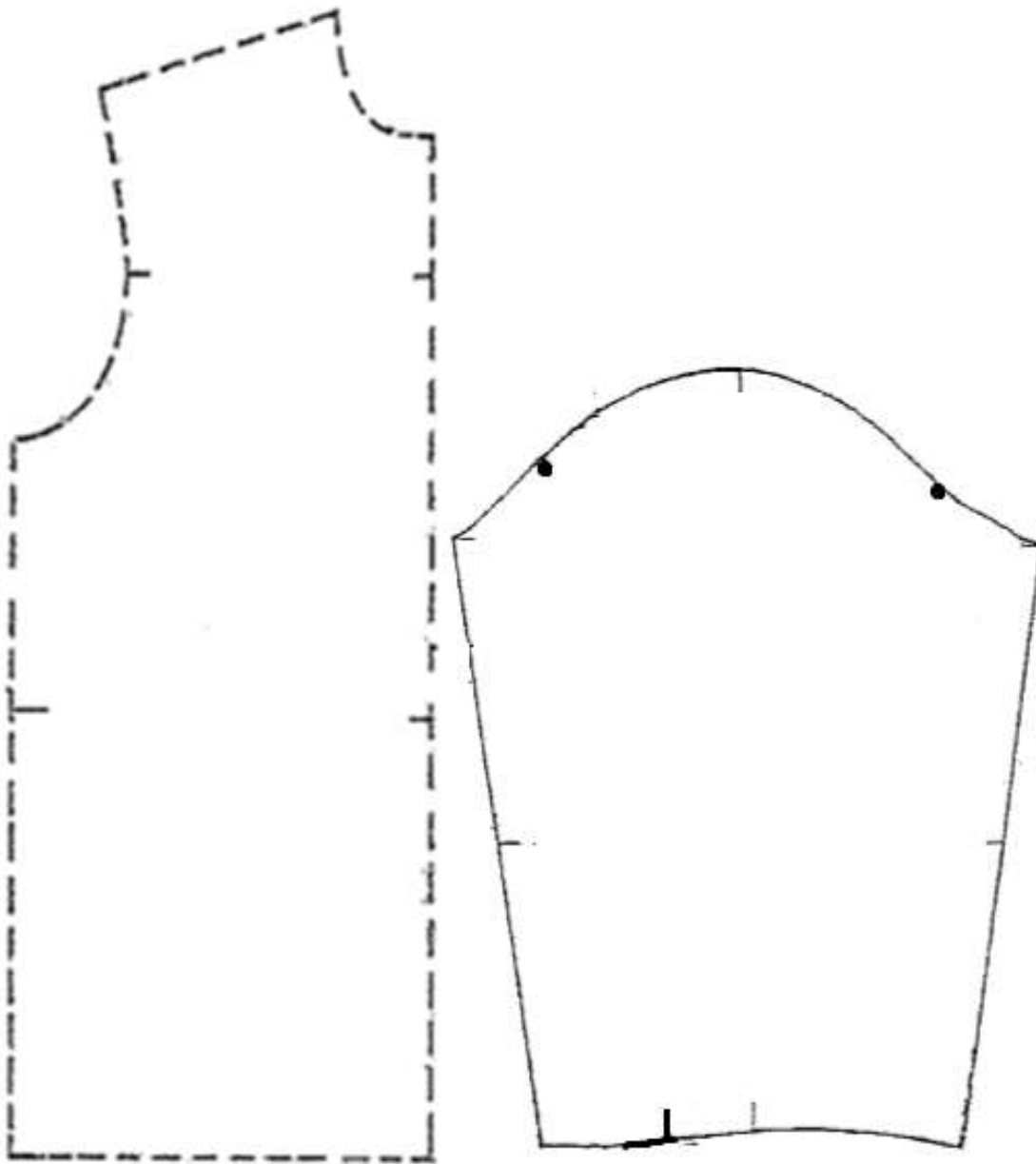

ADDENDUM D

